

Toll free: 888-660-5892
email: info@truxxx.com

TIRE FITMENT ADVICE
The best way to ensure proper tire fitment is to install the kit before purchasing your wheels and tires. Always test fit tires and wheels before purchasing.

VEHICLE RIDE WARNING!
Trucks with lift or level kits installed have a higher center of gravity. Aggressive and sudden direction changes may cause a tip over.

202020 Honda Ridgeline Lift and Level Kit

- This kit contains:
- 2 - Strut Caps (front)
 - 2 - Strut Caps (rear)
 - 2 - Sway Bar Links (front)
 - 1 - Hardware Pack
 - Instructions
 - Warranty Card
 - Stickers



Installation Tips

- Always use caution handling ABS or wheel sensor wiring. Avoid tension of any kind on wiring harness as this may cause damage or failure.**
1. Trucks are often not level side to side from the factory. Please measure before installation.
 2. Re-torque all hardware to manufactures specifications
 3. When aligning, to get the best tire wear use our supplied specifications. OEM specifications are for trucks with stock wheels and tires. Larger tires will wear differently.
 4. All instructions are written with vehicle on a 2-post lift with tires removed.

Front Installation

Step 1

Remove axle nut at hub. Remove the three upper strut mounting nuts from under the hood of the truck. Protect the CV boot with a rag or similar to prevent damage to rubber boot. Use caution with any ABS wiring to prevent damage. Remove sway bar links from the truck. Remove lower strut mounting bolts

Step 2

Install TRUXXX spacer on the strut as shown in Figure A. Note the twisted shape of the TRUXXX cap, the strut base will need to be rotated 180 degrees before reinstalling in the truck.

Step 3

Reinstall the strut assembly. It may be necessary to use a pry bar to aid in the re-installation. Install the new Truxxx sway bar links.

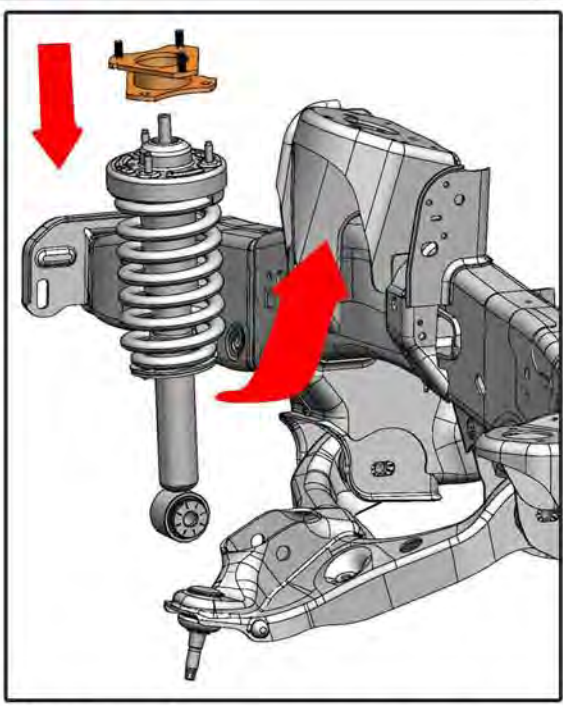

Figure A: Illustration is for reference only. Part dimensions will vary from kit to kit.



LIFT AND LEVEL KITS

SAFETY WARNING!
Always use the correct tools, and wear safety goggles. We **STRONGLY** recommend installation by a licensed mechanic on a properly secured locking lift.

Truxxx Manufacturing LLC
810 E 19th Street, Tucson AZ 85719

Toll free: 888-660-5892
email: info@truxxx.com

TIRE FITMENT ADVICE
The best way to ensure proper tire fitment is to install the kit before purchasing your wheels and tires. Always test fit tires and wheels before purchasing.

VEHICLE RIDE WARNING!
Trucks with lift or level kits installed have a higher center of gravity. Aggressive and sudden direction changes may cause a tip over.

202020 Installation Instructions Continued

Rear Installation

Step 4

Use caution with any ABS wiring to prevent damage. Disconnect sway bar links, and loosen lower control arm bolts at frame. Remove bolt attaching lower arm to spindle. Remove lower strut mounting bolt and upper strut mount nuts and remove strut.

Step 5

Install TRUXXX spacer on the strut. Note the twisted shape of the TRUXXX cap, the strut will be rotated 180° when reinstalled. Reinstall the strut assembly in reverse of dis-assembly. A pry bar may aid in installation of the strut. Lower truck to the ground before tightening lower control arm to frame bolts. Verify that all hardware has been tightened to the proper torque specs.

Alignment notes:

We recommend that a technician with experience doing alignments on lifted trucks perform the alignment. Large tires wear differently than OEM sized tires. Always do an alignment after changing tires on a vehicle.

Front Alignment Specs

	Left	Right
Caster (degrees)	N/A	N/A
Camber (degrees)	-1/4 or -.25	-1/4 or -.25
Toe	0	
Special Tools	none	

Rear Alignment Specs

	Left	Right
Caster (degrees)	N/A	N/A
Camber (degrees)	-1/4 or -.25	-1/4 or -.25
Toe	1/16 or .0625 toe in	
Special Tools	none	